

1	2	3	4	5				
No.	NAME	MATERIAL	DWG/MATL No.	CODE	Q'TY	SIZE	WEIGHT	REMARK
					0			

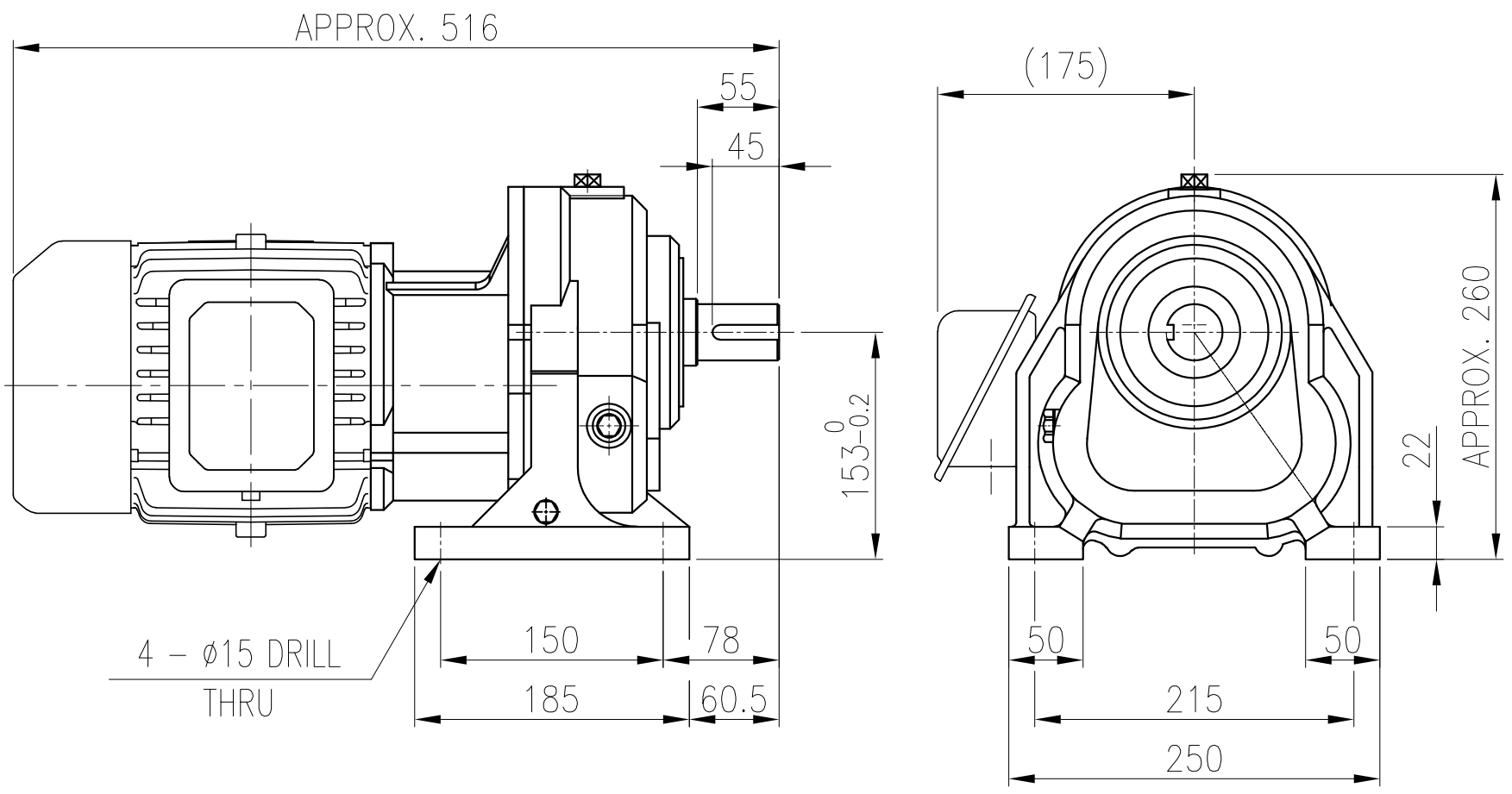
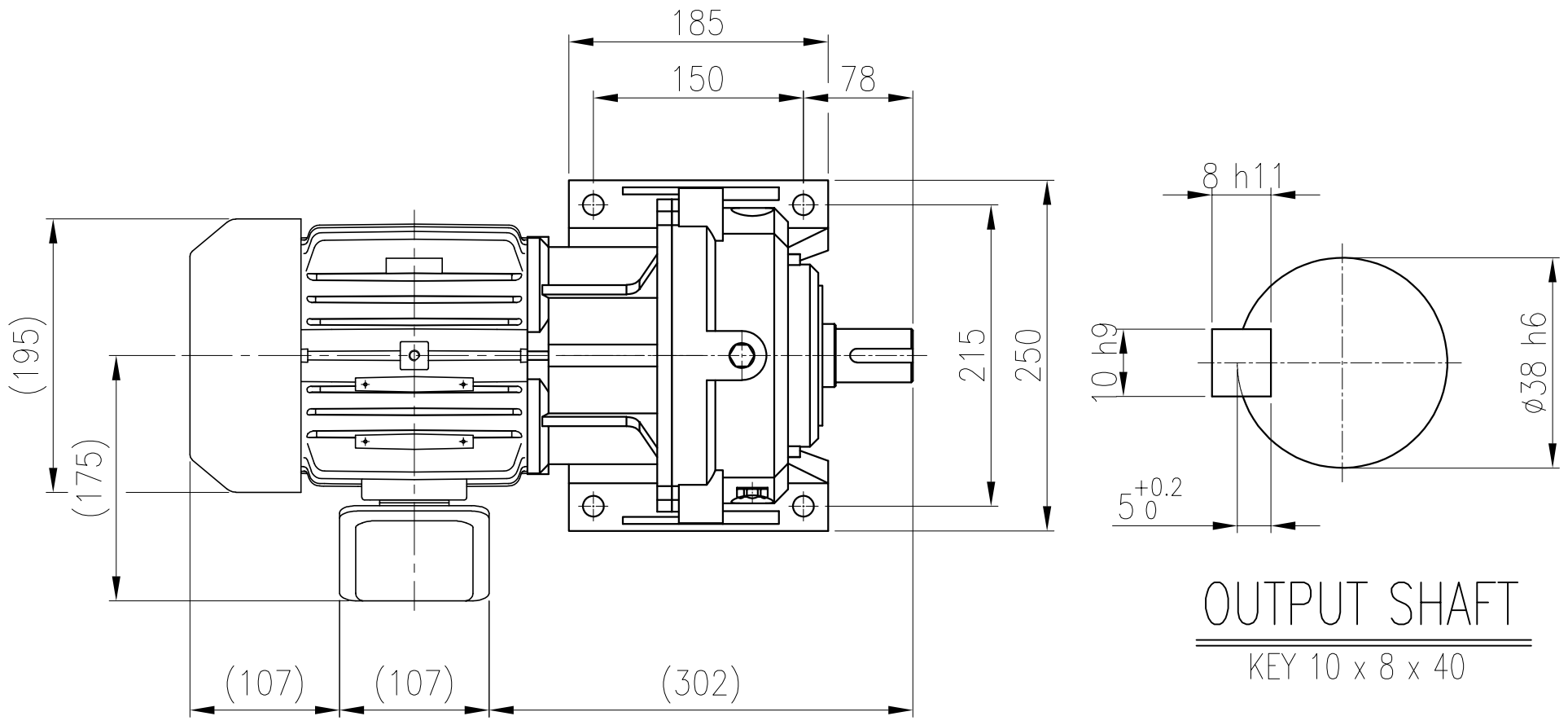

OIL SEAL		BEARING			
MOTOR SHAFT	D(M) 25 x 38 x 8	2ND PINION	6204ZZ	6304ZZ	GREASE : NLGI(EP)00
OUTPUT SHAFT	D(M) 45 x 62 x 12	3RD PINION	-	-	ABOUT 0.56 kg
		OUTPUT SHAFT	PM3030	6309ZZ	WEIGHT 52.79 kg

DWG NAME		외형도 OUTLINE DIMEASION					
DWG No.		EK2D007663H001		UNIT	mm		
				SCALE	1:1		
No.	DATE	DESIGNED	CHECKED	REVIEWED	APPROVED	DATE	2019-01-21
		2019.01.21	2019.01.21	2019.01.21	2019.01.21	REVISION No.	00
		하슬기	문병선	박희성	홍원철	THIRD ANGLE PROJECTION	
REF. No.							(A)

**HYOSUNG HEAVY INDUSTRIES**

TYPE 15Fr(1.5kW)\_5~30:1\_프리미엄

A4(210X297mm)  
FORM  
CE-14-0100-4A4  
2013.11.20

이 도면상에 표시된 정보는 호성중공업(주)의 소유이며 당사의 사전 서면동의 없이 무단사용을 금합니다.